

INSTRUCTIONS

REPAIR PARTS LIST AND WARRANTY INFORMATION

WPO50 Trough Drinker

READ ALL DIRECTIONS CAREFULLY BEFORE BEGINNING INSTALLATION

⚠ WARNING ⚠

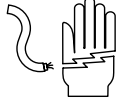

1. INSTALLATION MUST BE MADE AND MAINTAINED IN STRICT ACCORDANCE WITH NATIONAL/LOCAL PLUMBING AND NATIONAL/LOCAL ELECTRICAL CODES (CSA IN CANADA). INSTALLATION MUST BE MADE BY A QUALIFIED ELECTRICIAN. THE APPLICABLE PROVISIONS OF THE ABOVE MENTIONED CODES TAKE PRECEDENT. IMPROPER ELECTRICAL INSTALLATION AND MAINTENANCE MAY RESULT IN SERIOUS INJURY OR DEATH FOR PERSONNEL OR ANIMALS.
2. EACH ELECTRICAL UNIT MUST BE WIRED THROUGH A FUSED SWITCH BOX AND FUSED ACCORDING TO AMPS REQUIRED FOR EACH SPECIFIED ELECTRICAL UNIT. CANADIAN ELECTRICAL CODE--PART 1 REQUIRES ANIMAL WATERERS INSTALLED IN FEEDLOTS IN OPEN FEEDING AREAS TO BE GROUNDED BY A SEPARATE STRANDED COPPER GROUNDING CONDUCTOR OF AT LEAST NO. 6 AWG TERMINATING AT A POINT WHERE THE BRANCH CIRCUIT RECEIVES ITS SUPPLY.

Ref. No.	Item Number	Description	Qty
A	WPO7010A	Valve Cover Assembly	1
	1 OF514	Screw, 1/4" x 1/2" Slotted Hex Washer Head, SS	2
	2 WPO7013	Bracket, Valve Cover, SS	1
	3 OF571	Spring, No. 14576 .48" OD x 1.75", SS	1
	4 OF570	Washer, No. 14575 .344 ID x .750 OD, SS	1
	5 OF573	Cover Pin, No. 14753, 4 1/2" L, SS	1
	6 OF572	Cotter Pin, No. 14575 .94 ID x .75", SS	1
	7 WPO7010	Valve Cover	1
B	WPO5011A	Drinker Base	1
C	WPO7012A	Access Door Assembly	2
	8 OF541	Roll Pin, 1/8" x 1", SS	1
	9 WPO7012	Access Door	1
	10 VK17	Spring, SS	1
	11 OF543	Fillister Head Bolt .25" x 2.238" Usuable, SS	1
D	WPO5014	Supply Line Assembly	1
	12 OP223	3/4" NPT Hex Plug	1
	13 OP114	Tee, 3/4" FIPT Schedule 80, PVC	1
	14 OP295	Reducer Bushing, 3/4" x 1/2"	1
	15 VP224	Valve Assembly 1/4" Orifice	1
	15.1 VP115	Adjusting Screw, Poly	2
	15.2 VA6B	Float Arm, 6" Poly	1
	15.3 VM117	Float, Poly 4 3/8" Diameter	1
	16 OP337	Close Nipple, 3/4" NPT, 2", PVC	2
	17 B83	Conduit Lock Nut, 3/4" x 1 5/16" x 1/8"	2
	18 WPO2514	Valve Attachment Plate, SS	1
	1 OF514	Screw, 1/4" x 1/2" Slotted Hex Washer Head, SS	3
	19 OP80	Elbow, 3/4" x 3/4", PVC	1
	20 OP215	Hose Barb, 3/4" NPT x 3/4", PVC	2
	21 OP214	Clamp, Worm Gear, 1/2"-1", SS	2
	22 49-1465-27	Supply Hose, 3/4" x 27"	1
	23 OP211	Shutoff Valve, 3/4" NPT, 1/4" Turn, PVC	1
	24 OP210	1 1/2" NPT Pipe Plug	1
	25 OP299	Plug, Mechanical, 882-3, 3"	1
	383344	Stud Anchor, 3/8" x 3 3/4", SS, Pack of 4 (Not Shown)	1
	ISHWPO50	Instruction Manual (Not Shown)	1



PO BOX 2000 • HOUGHTON, IOWA 52631 • USA
 PH: 319-469-4141 FAX: 319-469-4402
 WEB: www.hawkeysteel.com E-MAIL: sales@hawkeysteel.com



ISHWPO50
 REV. 3.3
 PRINTED IN U.S.A.

Exhibit A: WP07010A

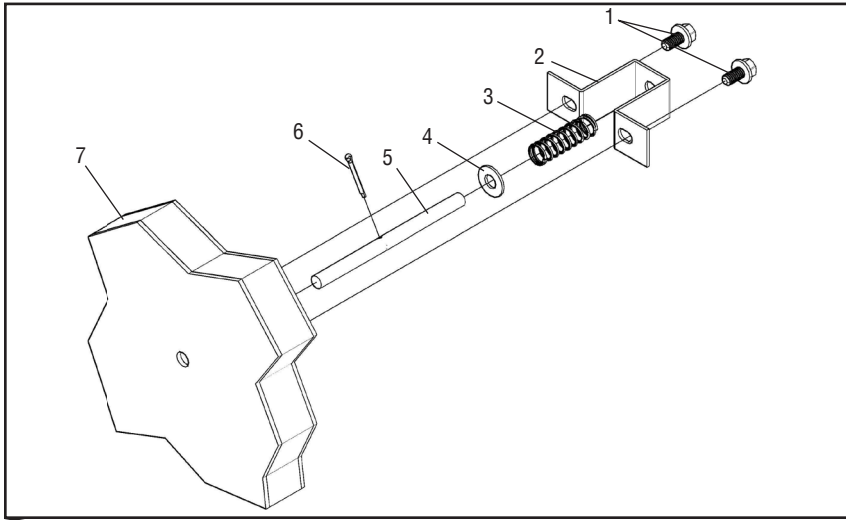

See Exhibit D: WP05014

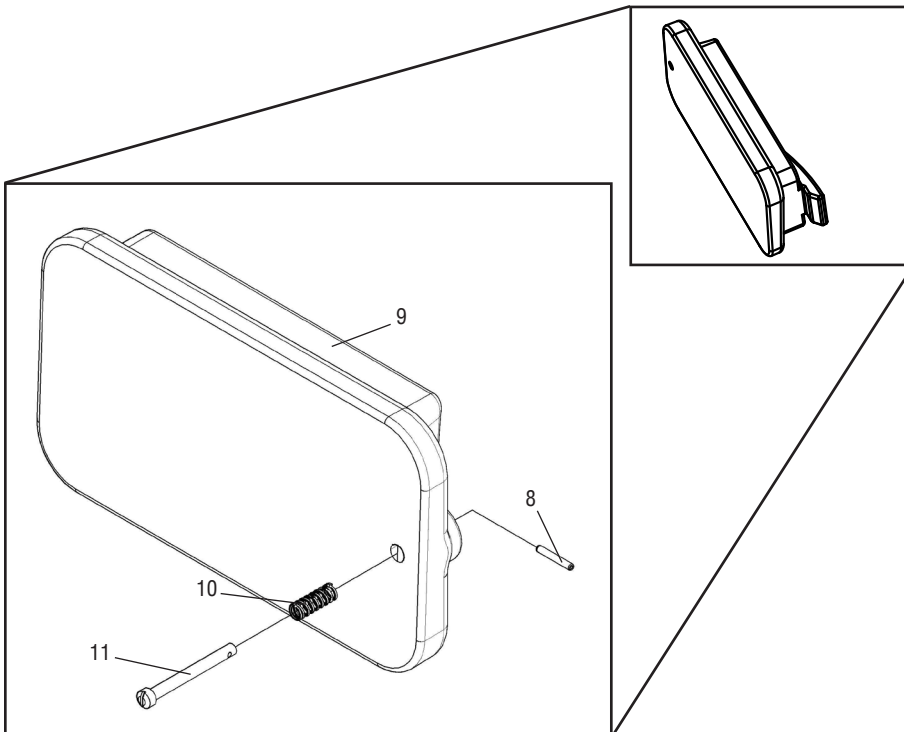
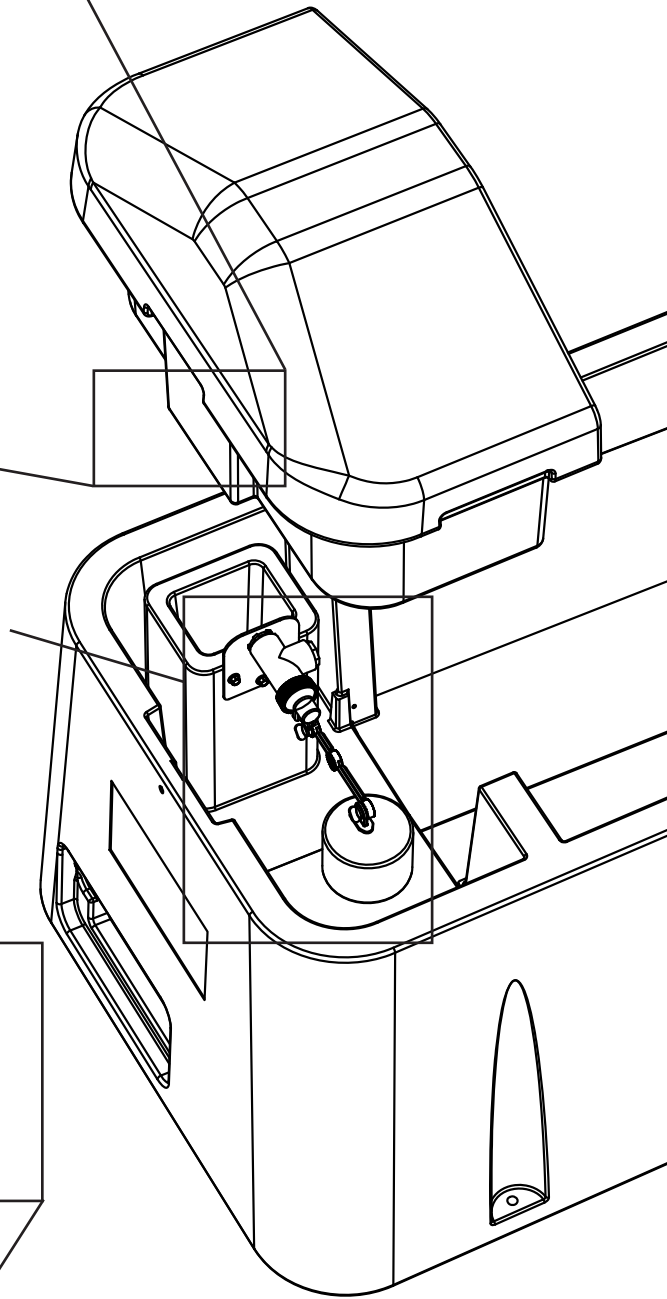

Exhibit C: WP07012A



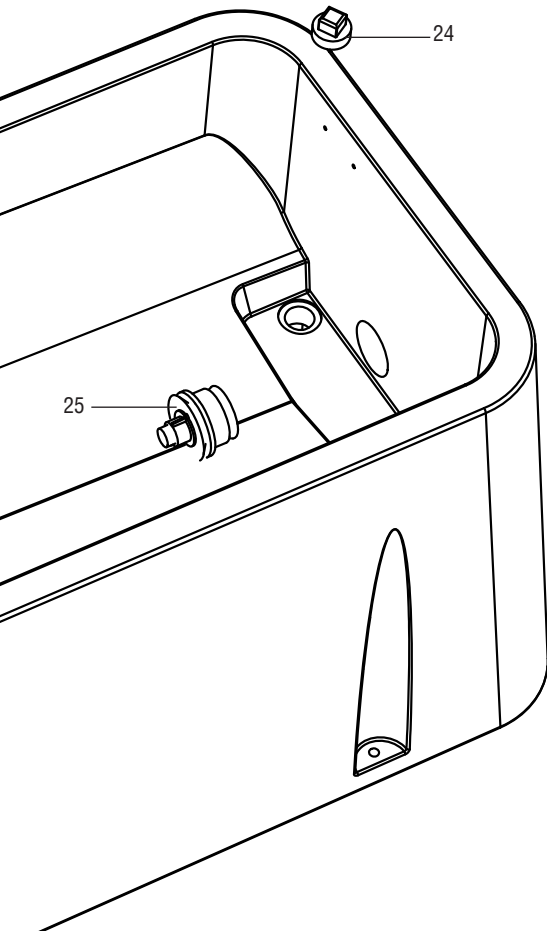
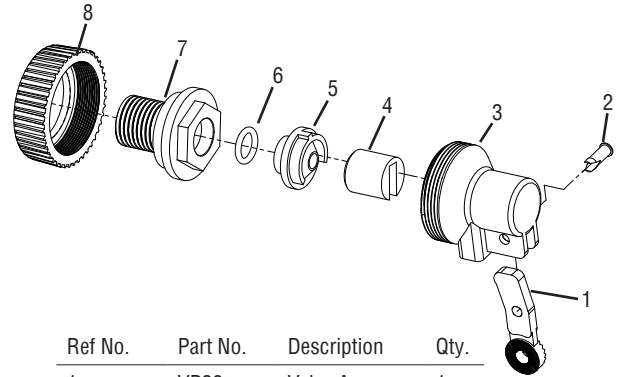
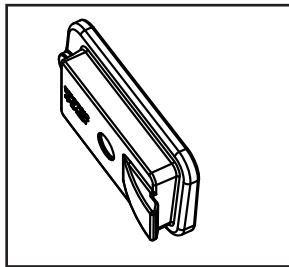

Exhibit B: WPO5011A

See Exhibit C: WPO7012A



Ref No.	Part No.	Description	Qty.
1	VP29	Valve Arm	1
2	VM106	Link Pin	1
3	VP21	Body	1
4	VP28	Plunger	1
5	VP26	1/4" Orifice	1
6	VP112	O-Ring	1
7	VP13	3/4" NPT Base, Poly	1
8	VP15	Assembly Nut	1

- VP28 Plunger comes with a rubber insert.
The rubber insert cannot be ordered separately.

Exhibit D: WPO5014

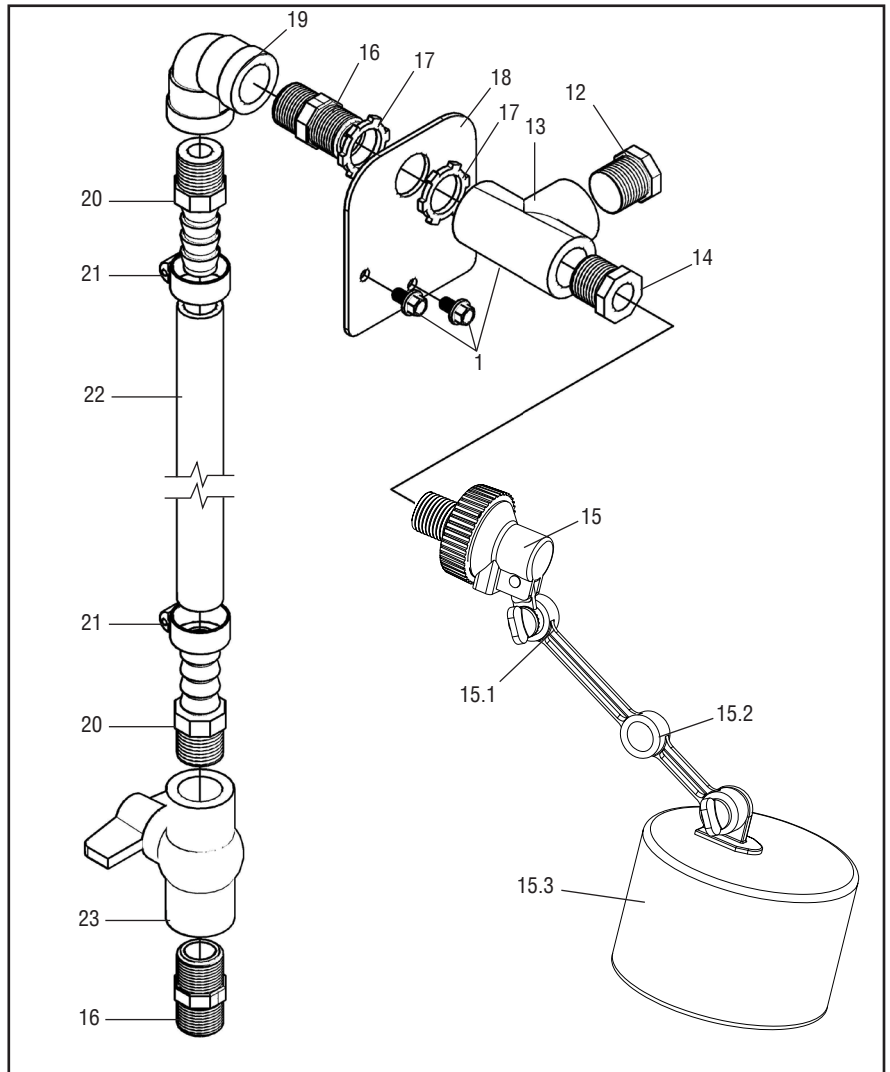

IMPORTANT: Our Model WPO50 Trough Drinker must have a neck rail installed over it. No neck rail in place will void the warranty.

To install the valve cover, depress Ref. No. 5 stainless steel cover pin. Place cover into position. Let pin snap back out into the hole in the end of the trough. To remove valve cover, depress the cover pin through the hole in the end of the trough. Lift one side so that the pin snaps back outside of and above the trough. Use the handholds to help lift the cover.

To open access doors on the trough, use a straight blade screwdriver. Turn Ref. No. 11 fillister head bolt one quarter turn and the bolt should pop out.

Use the mechanical plug (Ref. Nos. 25) inside the trough.

WPO50 DRINKER FOOTPRINT Dimensions in Inches

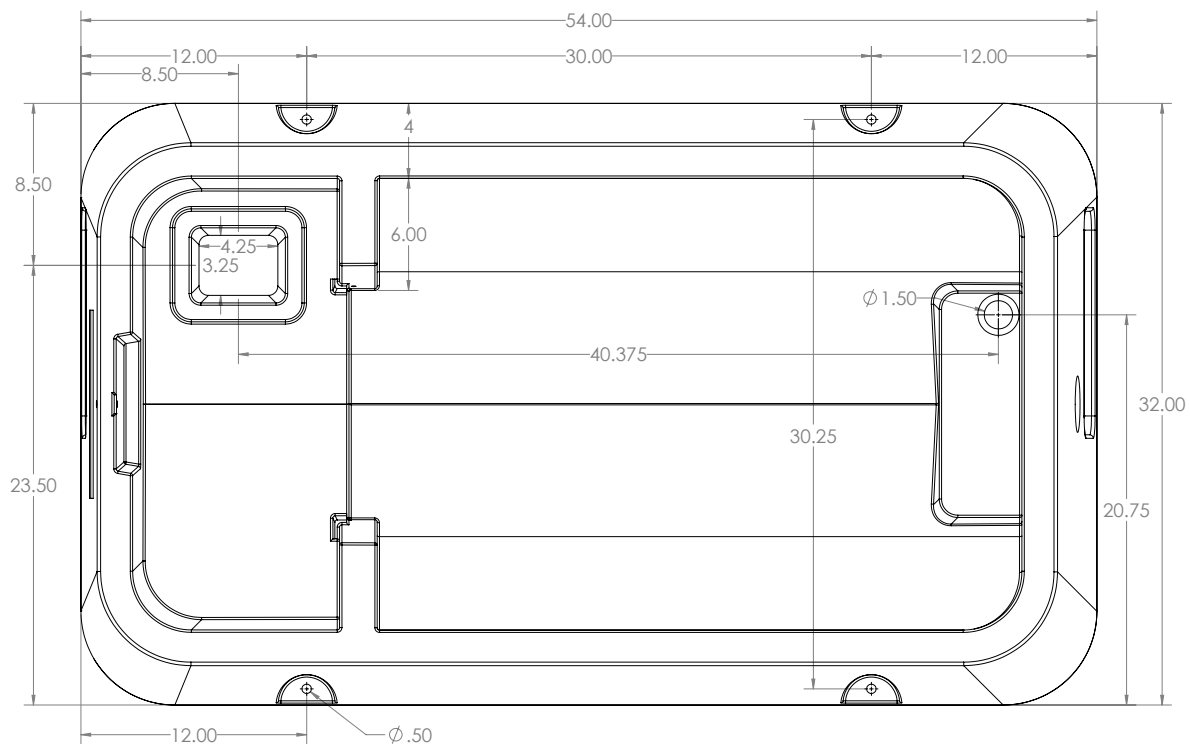

LIMITED WARRANTY

Our Utility Deicer (heater) and our Valve (including float arm, float and adjust screw) carry an 18 month limited warranty. All other components of Hawkeye Steel Products, Inc. Performance One E-Drinks are covered by a five year limited warranty. After the five year warranty period, all components, except valve and heater parts, are covered by an additional 6 year pro-rated warranty. Both warranty periods are from the date of purchase. Each drinker must be registered with Hawkeye Steel Products, Inc. on the card which accompanies each drinker. Warranted components should be returned to your dealer for shipment to our factory -- Highway 16 West, P.O. Box 2000, Houghton, IA 52631 USA, Fax 319-469-4402; 800-553-1791. Warranty is limited to the repair or replacement of components. The warranty does not cover removal or reinstallation; cost to transport and retrieve components for repair; damage or loss occurring during transport; damage due to foundation design; damage caused by natural or environmental conditions (acts of God); costs associated with loss of time and/or inconvenience or any other consequential damages; injury; lack of animal performance; loss of profit, life or property; malfunction resulting from misuse, improper installation, no installation of a neck rail, lack of maintenance (such as not periodically removing deposits on the deicer if used), other negligence or unauthorized alteration. All provisions stated on the back of Hawkeye Steel Products, Inc.'s invoice apply and Hawkeye Steel Products, Inc. assumes no consequential damages.